

SUPERBOLT TENSIONERS

Installation & Removal Instructions

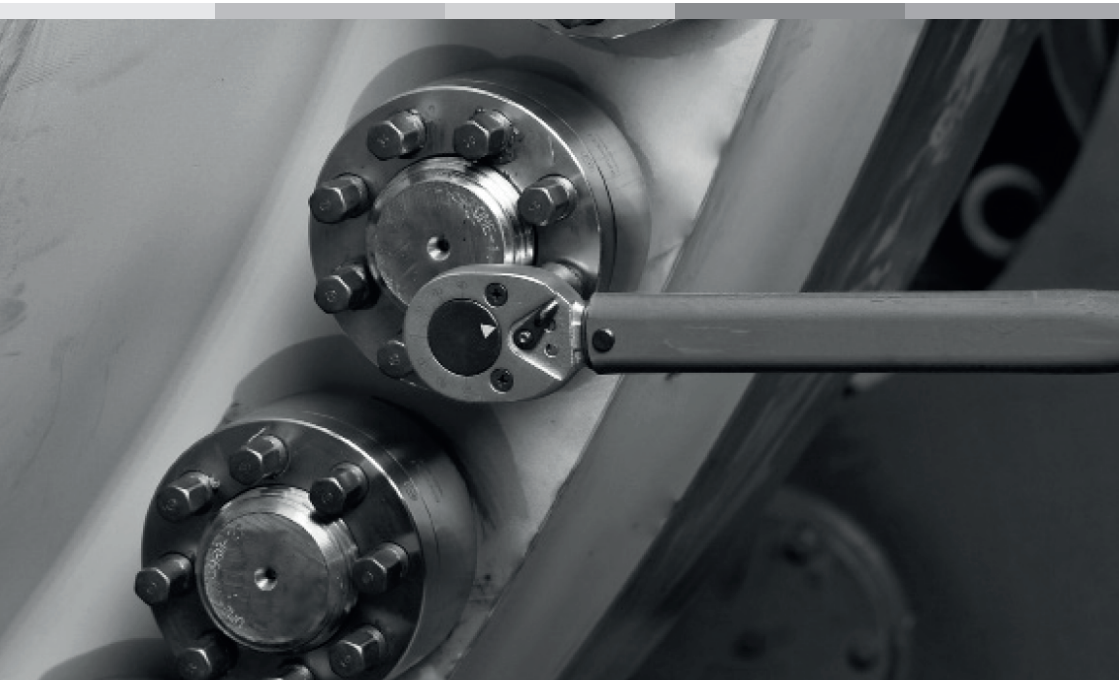

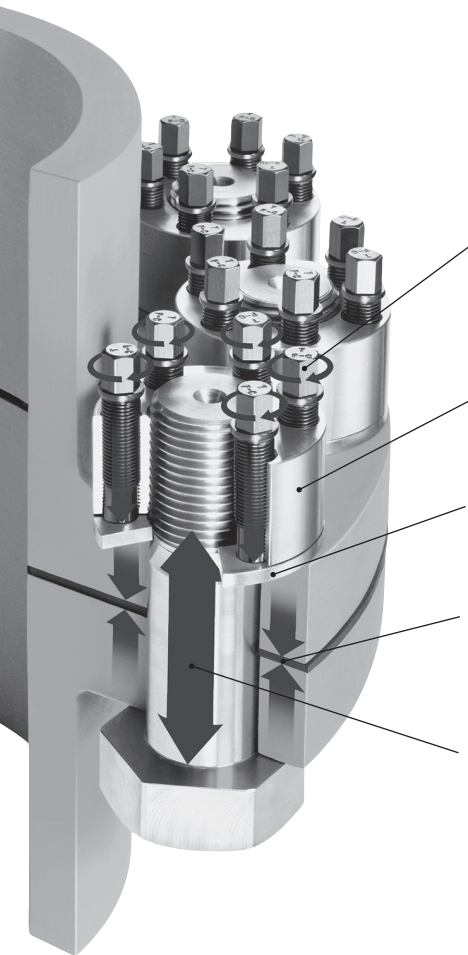

How Superbolt tensioners work:

By turning the jackbolts, a strong thrust force is generated and directed against a hardened washer. The jackbolts have a small friction diameter creating a high thrust force for relatively little torque.

The loads are transferred through the nut body which is positioned on the main thread by hand.

A hardened washer is used to transfer the force while protecting the flange face and nut body.

The thrust force of many jackbolts and the opposite reaction force of the main bolt head create a strong clamping force on the flange.

The thrust (axial) force from the jackbolt creates an equally strong reaction force in the main bolt.

Instructions

With Superbolt™ tensioners you have chosen a technologically superior product. It is purely mechanical and, therefore, very safe.

The following simple steps will help you with your application. By following these instructions you can increase safety, reduce downtime and extend service life.

Content	page/s
1. Tightening procedure	4/5
2. Loosening procedure	6/7
3. Lubrication and tools	8/9
4. Maintenance	10
5. General notes	11
6. Contact	12

These instructions are valid for Superbolt standard pretensioning systems according to Nord-Lock AG data sheets:

Tensioners:

- MT / MTT / MTL / MTA
- MR / MRA
- CY
- SJ / SJL / SJX
- GR2
- SM
- H650 / H650T
- H850 / H850T
- SH / SHT
- PV350C / PV450C

Torquebolts:

- SB8
- SB12
- SBU
- SSJ

1. Tightening procedure

1.1 Check:

- What is your jackbolt torque?
Recommended torque M see
- Your internal directives
 - Nord-Lock AG certificate
 - Nord-Lock AG data sheet

Attention: The jackbolt torque engraved on the tensioner body is the maximum value which may be unsuitable for your application. The indicated torques are theoretical values. The achieved elongations of the studs are relevant.

If you are unsure, contact your nearest Nord-Lock office.

1.2 Which tools?

- Suitable torque wrench
- Matching socket, heavy duty line
- Lubricant

1.3 Preparation:

- Clean main thread and contact areas and lubricate well with suitable anti-seize lubricant (A), put on washer (B).
- Make certain that the jackbolts on the Superbolt tensioner do not protrude beyond the load surface and are well lubricated. If necessary, relubricate with the recommended Superbolt lubricant (see certificate).
- Firmly tighten the tensioner by hand (D).
- Afterwards turn back approx. 1/4 turn. Depending on size the gap will be approx. 1 to 3 mm wide (E).

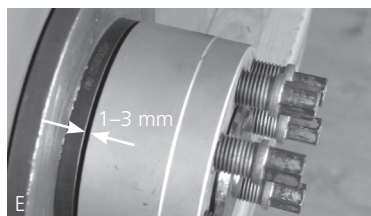
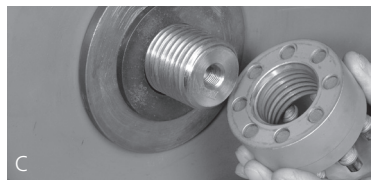
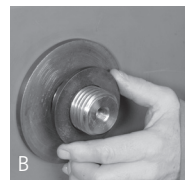
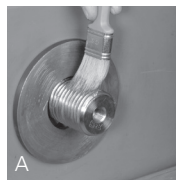

1.4 Tightening:

Step 1:

Tighten 4 jackbolts by hand or using a small wrench to center the main thread and to eliminate clearances. Tighten bolts crosswise.

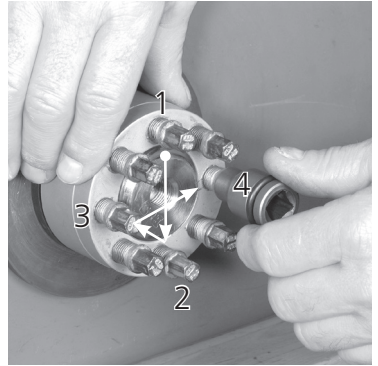

Step 2:

Now tighten these same 4 jackbolts crosswise with 50% of the recommended jackbolt torque.



Step 3:

Tighten the same 4 jackbolts crosswise with 100% of the recommended jackbolt torque.



Step 4:

Now change to a circular tightening pattern and tighten all jackbolts with 100% of the recommended jackbolt torque.



Step 5:

Repeat step 4 until all jackbolts are equally tightened (less than 10° remaining movement). Normally 2 to 4 passes are sufficient, however with longer bolts more may be needed.

Suitable power tools can save time, see item 3.3.

2. Loosening procedure

Warning! Loosening requires an exact procedure. The jackbolts must be unloaded gradually! Under no circumstances unload single jackbolts completely. The remaining jackbolts would have to carry the entire load and, therefore, would be difficult to loosen. In extreme cases the jackbolts could deform and make loosening impossible!



2.1 Usage at normal temperatures (< 100 °C)

Preparation: Before loosening apply penetrating oil, especially if any rust has formed.



Step 1:

Starting with N° 1 (arbitrary) loosen every jackbolt in a circular pattern approx. 1/4 turn (breaking loose is sufficient). After the first round jackbolt N° 1 will be tight again, however, with a lower load level.

Note: Should several tensioners be loosened, i.e. on a flange, perform step 1 on all tensioners before moving to step 2.

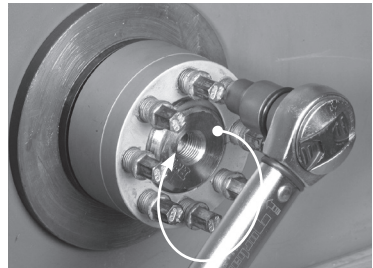

Step 2:

Repeat step 1, again on all tensioners if applicable.

Step 3:

Repeat step 1 for a 3rd time.

Step 4:

Relieve jackbolts completely. Now the tensioner can be removed by hand.

Note: Long studs or bolts expand more and, therefore, may require one or two additional passes.

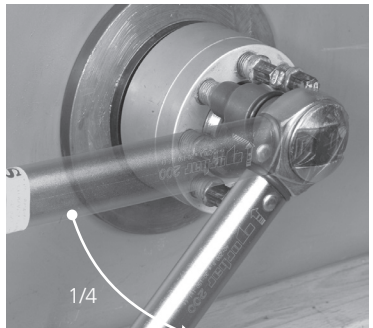

Attention: Before re-using follow maintenance instructions!

2.2 Usage at high temperatures (> 100 °C)

Preparation: At higher temperatures the petroleum base of the lubricant evaporates, thereby increasing the effort for loosening.

Step 1:

If possible, apply penetrating oil during cooling of the installation (at approx. 150 °C). At higher temperatures use synthetic oil.

Step 2:

Starting with N° 1 jackbolt (arbitrary) break loose each jackbolt of one tensioner in a circular pattern.

Note: Do not undo any jackbolts beyond break loose point. If multiple tensioners are used in the joint, apply procedure to all tensioners before moving onto the next stage.

Step 3:

Complete the loosening procedure described under item 2.1 (normal case), beginning with step 1.

Note: For high temperature applications bolts with bores are often used. The use of heating rods when loosening the tensioners will speed up the process. Five minutes heating will be sufficient to accelerate the process.

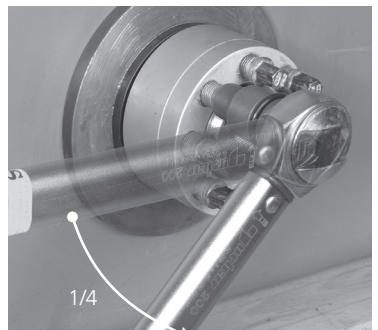
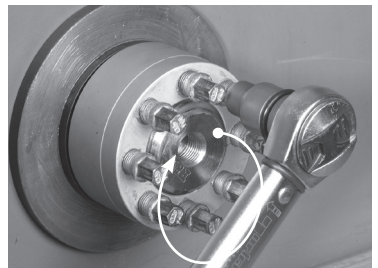
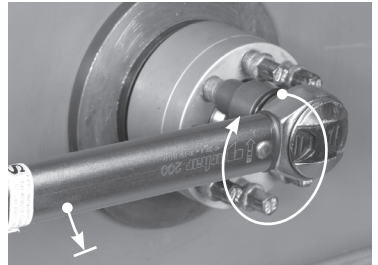

3. Lubrication and tools

3.1 Lubricant

Jackbolts: The jackbolts are delivered pre-lubricated and are ready for use. Refer to the certificate for the lubricant. For jackbolts use only Superbolt lubricants or substitutes permitted by Nord-Lock AG.

Hardened washers: For the upper face (contact with jackbolts) use the correct Superbolt lubricant. For the bottom face you may use any suitable anti-seize lubricant.

Main thread: Any suitable anti-seize lubricant including Superbolt lubricants may be used. Apply with brush or spray.



3.2 Sockets

For tightening the jackbolts only high quality tools in good working order should be used. Heavy duty 6pt sockets for use with impact tools are best suited. Worn sockets are dangerous and should be disposed of.

3.3 Power tools

Air impact tools have proven to be most suitable. However, with Superbolt jackbolts they reach only 30...50% of their rated output. Therefore, the largest possible air lines and couplings should be used. Impact tools are suitable to a torque of max. 200 – 250 Nm. Pneumatic wrenches are recommended for large torques, which offer the same control as the impact tools.



3.3 Power tools (continuation)

Adjustment of the correct torque: Tighten one jackbolt to the desired torque with the torque wrench. Then, apply the air impact tool and increase the pressure until the jackbolt starts turning again.

Verifying the torque output of an air impact tool is easy: Tighten until tool stalls, then measure the torque with a torque wrench (preferably with electronic gauge).

When tightening air impact tools are especially suited for steps 2 through 5 and should be adjusted to approx. 90 to 100% of the rated torque.

Important: Because of the lower accuracy of power tools, the last tightening round should always be performed manually with a precision torque wrench.

Attention: Only use air impact tools for tightening, never for loosening.

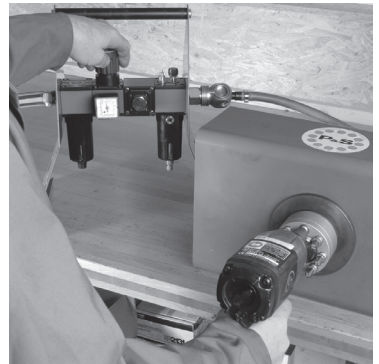
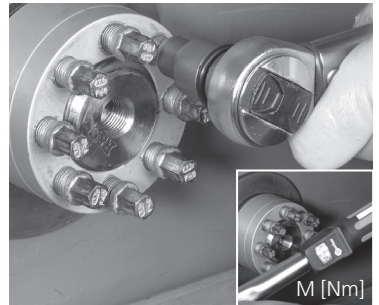
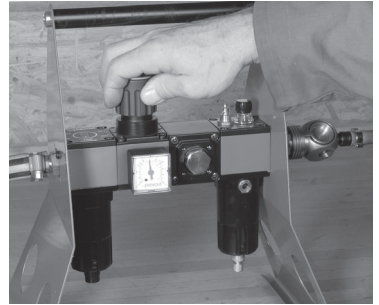

Notes for the use of air impact tools:

Network pressure min. 6,5 bar

- up to 70 Nm 3/8" impact tool or air ratchet
- 70-130 Nm 1/2" impact tool, derated (**Attention:** Do not overshoot!)
- 130-200 Nm 1/2" impact tool
- 200-270 Nm 1/2" impact tool (handy) or 3/4"
- over 270 Nm 3/4" impact tool or 1"
- over 400 Nm 3/4" air impact tool with reaction arm

4. Maintenance

4.1 Regular checks

Properly designed bolted connections utilizing Superbolt tensioners maintain their preload in service provided that they are correctly tightened. During inspections the preload can be checked. Use a torque wrench adjusted to 100% of the permitted jackbolt torque according to the certificate or your installation procedure.

Should jackbolts unexpectedly have lost some of the preload the following procedure is recommended:

- Loosen and remove a single jackbolt. Clean and lubricate with the anti-seize lubricant specified in the Nord-Lock AG certificate. Then reinsert the jackbolt and retighten to the 100% level. Repeat for every jackbolt.
- Now retension according to tightening procedure – step 5, meaning:
Tighten in circular pattern with full jackbolt torque, until all jackbolts are tightened.

4.2 Preventive maintenance

i.e. for removal for maintenance purposes:

- Remove according to loosening procedure.
- Clean thread and end of the Superbolt jackbolts and relubricate according to certificate. Do not use molybdenum disulfide (MoS₂) unless expressly specified in the certificate.
- Superbolt hardened washers may be re-used despite indentations simply by turning over. Depressions of a few 1/100 mm are normal.
- Retighten according to tightening procedure.

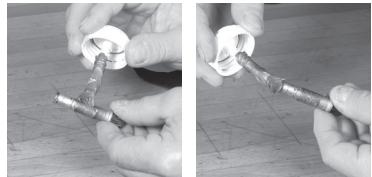

4.3 If encountering problems

Issue: Jackbolts cannot be loosened:

- Try to free at least one jackbolt.
- Remove, lubricate well and tighten with 110% of the recommended jackbolt torque.
- You should then be able to loosen the two neighboring jackbolts.
- Remove also, lubricate and tighten with 110%.
- Again the next two jackbolts should become free.
- And so on.
- Afterwards release all jackbolts according to loosening procedure.

Issue: Hardened washers are damaged i.e. after a long time in service:

- Replace with original Superbolt hardened washers.

Issue: Jackbolts are damaged or missing:

- Replace with original Superbolt jackbolts.
Do not use any other available bolts as they may not be suitable for such high loads.

For further information, please contact your closest Nord-Lock office.

5. General notes

5.1 Tightening of tensioners with only 4 or 6 jackbolts

Step 1: Tighten all jackbolts by hand crosswise.

Step 2: Tighten 2 opposite jackbolts with 50% of recommended torque.

Step 3: Tighten 2 other opposite jackbolts with 100%.

Step 4: Tighten jackbolts in circular pattern at 100% until fully tightened.

5.2 Tightening of long tie rods

To accelerate tightening of long tie rods we recommend to perform step 4 with increased jackbolt torque (approx. 110–125%).

Attention: In final rounds always check jackbolt torque is at 100% with a torque wrench to prevent overloading.

5.3 Gaskets with large elastic displacements

It is normal that some jackbolts (or tensioners in a multi tensioner application) become loose during flange tightening. Only those bolts being tightened carry loads. Do not spin down loose tensioners as this will cause problems later.

5.4 Tensioning of large flanges or joints

For tensioning large flanges/joints preferably work with 2 people 180° apart or 4 people 90° apart.

5.5 Usage of spacers

Tensioners should be positioned on the outer end of a bolt to protect the main thread. Place suitable spacer, or heavy washers under the hardened washer. Threaded areas that have been damaged can then be bypassed.

5.6 Installation tools

Apart from a variety of standard tools for tensioning of Superbolt tensioners simple special tools are available, which facilitate the installation of large nuts or bolts.

5.7 Protective caps

Made from vinyl, steel or stainless steel are available to protect the tensioners for different applications. Filled with grease they offer good protection against rust at normal temperatures.



6. Contact

For further information on possible uses, applications and maintenance of Superbolt pretensioning systems, please contact your local Nord-Lock office through **www.nord-lock.com/contact**

Exclusion of liability

While every effort has been made to ensure the correctness in the instruction manual, The Nord-Lock Group excludes all liability based on unsuitable product selection for specific applications, improper use as well as all types of damages resulting from disregarding our instructions and directives.

Changes due to technical progress are reserved to The Nord-Lock Group.

© Copyright 2017 Nord-Lock Group. NORD-LOCK, SUPERBOLT, BOLTIGHT and EXPANDER SYSTEM are trademarks owned by different companies within the Nord-Lock Group. All other logos, trademarks, registered trademarks or service marks used herein are the property of the Nord-Lock Group. All rights reserved.